

GYSIN Planetary Gearbox GPL 120

Rated torque in Nm (S1)	Type Standard
Rated torque in Nm (S1)	Type R Reduced
EMERGENCY STOP torque in Nm	
Rated torque in Nm (S5)	Type S Low backlash
Rated torque in Nm (S5)	Type V Heavy duty
EMERGENCY STOP torque in Nm	

1-stage		2-stage		3-stage	
Ratio (i)	Motor shaft $\varnothing D \leq$	Ratio (i)	Motor shaft $\varnothing D \leq$	Ratio (i)	Motor shaft $\varnothing D \leq$
*2	19	*10	14	49	19
3,5	24	12,25	24	56	19
4	19	14	19	64	19
5	14	16	19	70	19
6	10	20	19	80	19
		24	19	100	19
		25	14	120	19
		30	14	144	19
		36	10	180	14

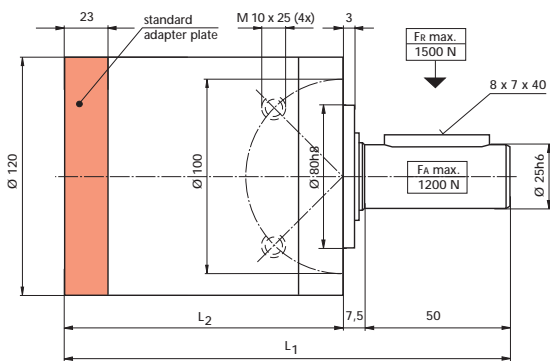
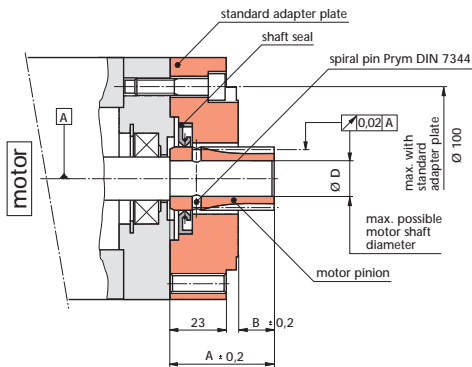

* Type Standard only



Technical and performance data:

Gearbox weight	kg	5	7,250	9,500
Dimension L1	mm	154	184	214
Dimension L2	mm	96,5	126,5	156,5
Dimension A	mm	48	44,5	44,5
Dimension B	mm	21	17,5	17,5
Efficiency at full load	%	96	90	85
Average mass inertia at drive	kgcm ²	1,750	1,400	1,350
No-load backlash Type Standard	arcmin \leq	20	35	50
No-load backlash Type V Heavy duty	arcmin \leq	20	35	-
No-load backlash Type R Reduced	arcmin \leq	10	20	30
No-load backlash Type S Low backlash	arcmin \leq	6	10	15
Torsional stiffness	Nm/arcmin	10	11	11
Rated speed at drive	min ⁻¹ \leq	3'000		
Max. rated speed at drive	min ⁻¹ \leq	5'000		
Temperature range	C	-30° / +90°		
Protection class	IP	54		
Service life	h	~10'000		

Stock programme • [Standard programme](#) • [Special programme \(on request\)](#)